

ORDINANCE 2018-01
CITY OF HIGHLAND, ARKANSAS

Page | 1

AN ORDINANCE PROVIDING MINIMUM ENERGY STANDARDS OR THE DESIGN OF NEW BUILDINGS AND STRUCTURES OR PORTIONS AND ADDITIONS TO EXISTING BUILDINGS THAT PROVIDE FACILITIES OR SHELTER FOR PUBLIC ASSEMBLY, EDUCATION, BUSINESS, MERCANTILE, INSTITUTIONAL, STORAGE, AND RESIDENTIAL OCCUPANCIES, AS WELL AS THOSE PORTIONS OF FACTORY AND INDUSTRIAL OCCUPANCIES DESIGNED PRIMARILY FOR HUMAN OCCUPANCY BY REGULATING THEIR EXTERIOR ENVELOPES AND THE SELECTION OF THEIR HVAC, SERVICE WATER HEATING, ELECTRICAL DISTRIBUTION AND ILLUMINATING SYSTEMS AND EQUIPMENT FOR EFFECTIVE USE OF ENERGY

Be enacted by the City Council of Highland, Arkansas

Section 1. ADOPTION OF ENERGY CODE.

There is hereby adopted by the City Council of Highland, Arkansas, for the purpose of establishing rules and regulations for energy efficient standards for new building construction, this Code known as the 2014 Arkansas Energy Code, being particularly the 2014 Arkansas Energy Code edition thereof and the whole thereof, save and except such portions as are hereinafter deleted, modified, or amended, of which not less than three (3) copies of this ordinance, as well as, three (3) copies of the 2014 Arkansas Energy Code, have been and now are filed in the office of the Clerk or Recorder of the City of Highland, Arkansas, and the same ordinance is hereby adopted and incorporated as fully as if set out at length herein, and from the date on which this ordinance shall take effect, the provisions thereof shall be controlling in the construction of all buildings and structures therein contained within the corporate limits of the City of Highland, Arkansas.

Section 2. INCONSISTENT ORDINANCES REPEALED.

Ordinances or parts thereof in force at the time that this ordinance shall take effect, if inconsistent herewith, are hereby repealed.

Section 3. EMERGENCY CLAUSE

Whereas it is of the utmost urgency that the city of Highland, Arkansas, have an up-to-date Energy Code to protect the citizens of our city, therefore, an Emergency is hereby declared to exist and this ordinance being necessary for the immediate protection of the public shall take effect immediately on its passage and approval.

APPROVED:

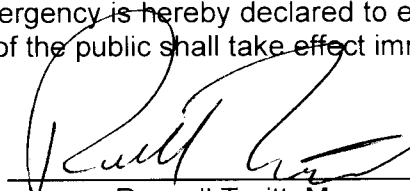
Russell Truitt, Mayor

PASSED: August 14, 2018
(Date)

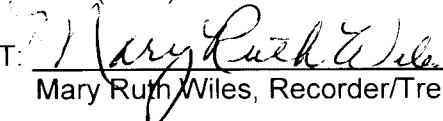
ATTEST: 
Mary Ruth Wiles, Recorder/Treasurer

I, the undersigned, **Mary Ruth Wiles**, do hereby certify that the above is a true and correct copy of an ordinance duly adopted by the City Council of Highland Arkansas, at a regular meeting duly convened on August 14, 2018

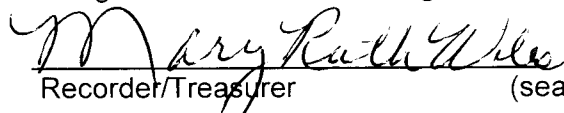
Recorder/Treasurer (seal)



Arkansas Energy Code for New Building Construction Supplements and Amendments

2014



Arkansas Economic Development Commission – Energy Office
900 West Capitol Avenue
Little Rock, Arkansas 72113
501-682-6103
www.arkansasenergy.org

Contents

Introduction.....	3
Overview.....	4
Arkansas Amendments.....	5
Chapter 1: Administration	5
Chapter 2: Definitions.....	8
Chapter 3: Climate Zones	9
Chapter 4: Residential Energy Efficiency	10
Chapter 5: Commercial Energy Efficiency	14
Chapter 6: Referenced Standards.....	15
Appendices	16
APPENDIX A: SAMPLE ORDINANCE	17
APPENDIX B: AIR SEALING KEY POINTS.....	18

Introduction

The Arkansas General Assembly authorized the Arkansas Economic Development Commission - Energy Office to promulgate these regulations in Section 3(B)(2)(c) of Act 7 of 1981. These rules and regulations are in adherence with the Administrative Procedures Act. The *2014 Arkansas Energy Code for New Building Construction* establishes minimum energy requirements for residential and commercial buildings in the State of Arkansas.

Residential and Commercial

For residential and commercial structures, Arkansas adopts the International Energy Conservation Code (IECC), 2009 Edition, published and copyrighted by the International Codes Council.

To order copies of the *International Energy Conservation Code 2009 Edition* contact:

International Code Council
900 Montclair Road
Birmingham, Alabama 35213-1206
Phone: 1-800-786-4452, Fax: 205-591-0775
Telecommunications Device for the Deaf: 205-599-9742
Copyright © 1996-1998 Southern Building Code Congress International, Inc. All rights reserved.
Web: www.iccsafe.org

Commercial

Chapter 5 of the IECC 2009 allows for an alternative compliance pathway for commercial structures through the American Society of Heating, Refrigerating, and Air Conditioning Engineers (ASHRAE) ANSI / ASHRAE /IESNA Standard 90.1-2007 Energy Standard for Buildings Except Low-Rise Residential Buildings. Both standards are available separately or in a bundled edition from the International Code Council at the above address.

To order copies of *American Society of Heating, Refrigerating, and Air-Conditioning Engineers ANSI/ASHRAE/IESNA Standard 90.1-2007* contact:

American Society of Heating, Refrigeration and Air-Conditioning Engineers, Inc.
1791 Tullie Circle, N.E.
Atlanta, Georgia 30329
Phone: 404-636-8400, Fax: 404-321-5478
Web: www.ashrae.org

Questions, inquiries or request for copies of the *2014 Arkansas Energy Code for New Building Construction Supplements and Amendments* may be addressed to:

Arkansas Economic Development Commission - Energy Office
Attn: *2014 Arkansas Energy Code for New Building Construction*
900 West Capitol Avenue
Little Rock, Arkansas 72201
Phone: 800-558-2633 or 501-682-6103, Fax: 501-682-7499
Email: EnergyInfo@ArkansasEDC.com

Overview

The INTERNATIONAL ENERGY CONSERVATION CODE, 2009 Edition (IECC 2009), published by the International Code Council, when used in conjunction with these State of Arkansas Supplements and these Amendments to the Arkansas Energy Code for New Building Construction shall constitute the *2014 Arkansas Energy Code*. In cases where there are differences between these “Supplements and Amendments” and the IECC 2009 Edition, these “Supplements and Amendments” shall take precedence.

Each of the following Chapters of this document associates directly with the corresponding chapters of the IECC 2009 unless otherwise noted.

Air infiltration accounts for substantial heat loss, heat gain and moisture migration in a building. Proper sealing around all doors, windows and other envelope penetrations through the walls, ceiling and foundation is as important to code compliance as are proper insulation R-values and assembly U-factors.

It is not the intention of this Code to abridge safety or health.

New buildings constructed shall comply with the provisions of this Code in a manner consistent with their obligations under Arkansas State law (see also the current version of the Arkansas Fire Prevention Code, Volume I Fire, Volume II Building).

These minimum standards shall not be construed as relieving the licensed builder or contractor of his or her responsibility for compliance with local ordinance, codes and regulations.

Arkansas Amendments

**Revise the International Energy Conservation Code, 2009 Edition, as follows:*

Chapter 1: Administration

CHAPTER 1 ADMINISTRATION

SECTION 101.1 SCOPE AND GENERAL REQUIREMENTS

***Delete 'Title' and replace with the following:**

101.1 Title. This Code shall be known as the *2014 Arkansas Energy Code for New Building Construction* and shall be cited as such. It is referred to herein as "this Code" or "the Arkansas Energy Code."

***Revise 101.5.1 'Compliance materials' to read as follows:**

101.5.2 Compliance materials. Compliance pathways for residential and commercial construction are those delineated in Chapter 4 and Chapter 5 respectively. Computer aided tools such as REScheck, RESNET Home Energy Rating System and COMcheck are also acceptable. Other tools and third-party services may be approved by the Arkansas Economic Development Commission – Energy Office.

A label as outlined in 401.3 is required to be posted on new residential construction.

REScheck and COMcheck are computer programs developed by Pacific Northwest National Laboratories for the U.S. Department of Energy (D.O.E.) to assist in demonstration of compliance with the IECC. They may be obtained free of charge from the D.O.E. online at www.energycodes.gov. When following the REScheck compliance pathway, select the appropriate version.

***Revise 101.5.2 "Low energy buildings' to add the following to the list of exempt buildings:**

3. Temporary use structures such as hunting and fishing camps, boat houses, remote cabins, etc. that do not meet the definition of "dwelling units" in Section 202; General Definitions.

4. Mobile homes and manufactured housing.

**SECTION 102 ALTERNATE MATERIALS – METHOD OF CONSTRUCTION, DESIGN OR INSULATING SYSTEMS
PART 2 – ADMINISTRATION AND ENFORCEMENT**

SECTION 103 CONSTRUCTION DOCUMENTS

***Add section 103.6 ‘Design Professional’ as follows:**

103.6 Design Professional: Architects and engineers employed to prepare plans and specifications for new buildings shall ensure the plans and specifications comply with the provisions of this Code in a manner consistent with their obligations under Arkansas State law (see also the current version of the Arkansas Fire Prevention Code, Volume I Fire, Volume II Building).

**SECTION 104
INSPECTIONS**

***Revise Section 104 ‘Inspections’ as follows:**

104.1 General. Construction or work that must comply with this Code shall be subject to inspection by the Arkansas Economic Development Commission - Energy Office or its agent, or by the code official.

104.2 Final inspection. *Code officials* within a county or municipality who have adopted this Code and conduct final inspections as a part of their normal operations shall perform a final inspection and approval for buildings when completed and ready for occupancy.

104.3 Re-inspection. The Arkansas Economic Development Commission - Energy Office or its agent or *code official* may cause a structure to be re-inspected.

**SECTION 110
ENFORCEMENT**

***Add Section 110 ‘Enforcement and Adoption’ as follows:**

110.1 General. Enforcement of this Code shall be the responsibility of the Arkansas Economic Development Commission - Energy Office or local government.

110.2 Local Government. All counties, cities or municipalities that issue building permits for new building construction are required to adopt this Code for new construction, additions and renovation of existing structures. However, the local municipality shall not in any way modify the energy conservation standards in this Code or promulgate or adopt rules or regulations that are less stringent than this Code.

A local government may exercise other administrative and enforcement procedures that it deems necessary to affect the purposes of this Code, including, but not limited to, prior plan approval, building permit requirements, and inspections during the course of construction.

SECTION 111
Adoption

***Add Section 111 'Adoption' as follows:**

111.1 Adoption. Arkansas Code § 15-10-205(b)(3)(B) requires that any city or county in Arkansas which issues building permits for new building construction (referred to herein as “applicable cities or counties”) shall adopt the Arkansas Energy Code as amended.

111.1.1 Date of adoption: Applicable cities or counties shall adopt the Arkansas Energy Code prior to 12/31/2014.

111.1.2 Acknowledgement of Adoption. Upon adoption of the Arkansas Energy Code, applicable cities or counties are required to submit a copy of the adoption ordinance to the Arkansas Economic Development Commission - Energy Office. If the applicable city or county has not adopted the Arkansas Energy Code by 12/31/2014 the mayor and/or county judge is required to submit a letter to the Arkansas Economic Development Commission - Energy Office, no later than 60 days after this deadline, describing why the city or county is not in compliance with Arkansas Code § 15-10-205(b)(3)(B).

SECTION 112
EFFECTIVE DATE

***Add Section 112 'Effective Date' as follows:**

112.1 The effective date for this Code shall be is 1/1/2015.

CHAPTER 2 DEFINITIONS

**SECTION 202
GENERAL DEFINITIONS**

***Revise Section 202 GENERAL DEFINITIONS to include the following:**

EFFICIENCY, HVAC SYSTEM. The ratio of useful energy output (at the point of use) to the energy input in consistent units for a designated time period, expressed in percent.

Arkansas Economic Development Commission - Energy Office

RECOOLING. The removal of heat by sensible cooling of the supply air (directly or indirectly) which has been previously heated above the temperature to which the air is to be supplied to the conditioned space for proper control of the temperature of that space.

RECOVERED ENERGY. Energy utilized which would otherwise be wasted (i.e., not contribute to a desired end use) from an energy utilization system.

RESET. Adjustment of the set point of a control instrument to a higher or lower value automatically or manually to conserve energy.

**CHAPTER 3
CLIMATE ZONES**

**SECTION 301
CLIMATE ZONES**

*Replace Figure 301.1 with the following:

Figure 301.1 Arkansas Climate Zones

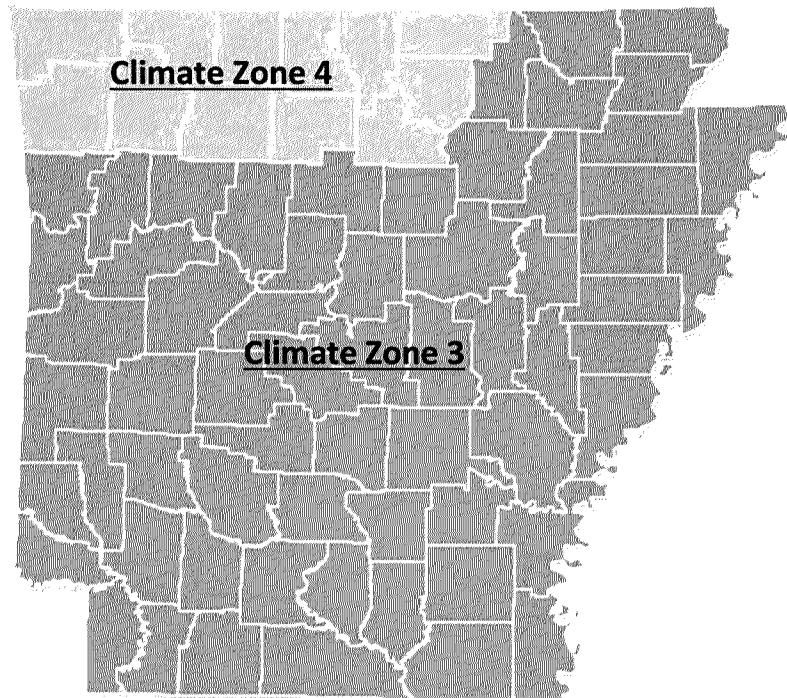

*Revise Table 301.1 to include on Arkansas-specific information as follows:

**TABLE 301.1
CLIMATE ZONES, MOISTURE REGINES, AND WARM-HUMID DESIGNATIONS BY STATE, COUNTY AND
TERRITORY**

Climate Zone 4 contains counties of Baxter, Benton, Boone, Carroll, Fulton, Izard, Madison, Marion, Newton, Search, Stone and Washington.

Climate Zone 3 contains counties of Arkansas, Ashley, Bradley, Calhoun, Chicot, Clark, Clay, Cleburne, Cleveland, Columbia, Conway, Craighead, Crawford, Crittenden, Dross, Dallas, Desha, Drew, Faulkner, Franklin, Garland, Grant, Greene, Hempstead, Hot Spring, Howard, Independence, Jackson, Jefferson, Johnson, Lafayette, Lawrence, Lee, Lincoln, Little River, Logan, Lonoke, Miller, Mississippi, Monroe, Montgomery, Nevada, Ouachita, Perry, Phillips, Pike, Poinsett, Polk, Pope, Prairie, Pulaski, Randolph, Saline, Scott, Sebastian, Sevier, Sharp, St. Francis, Union, Van Buren, White, Woodruff and Yell.

Chapter 4: Residential Energy Efficiency

CHAPTER 4 RESIDENTIAL ENERGY EFFICIENCY

SECTION 401 GENERAL

Arkansas Economic Development Commission - Energy Office

Revise 401.3 'Certificate.' as follows:

401.3 Label. A permanent label shall be posted on or in the electrical distribution panel. A temporary, but identical, label shall be posted on a clearly visible location for consumers on or in close proximity to the front door of the home. The temporary label shall remain affixed until purchase of the home. The permanent label shall not cover or obstruct the visibility of the circuit directory label service disconnect label or other required labels. The label shall be completed by the builder. The certificate shall list the predominant R-values of insulation installed in the or on the ceiling/roof, walls, foundation (slab, basement wall, crawlspace wall and/or floor) and ducts outside conditioned spaces; U-factors for fenestration and the solar heat gain coefficient (SHGC) of fenestration. Where there is more than one value for each component, the label shall list the value covering the largest area. The label shall list the types and efficiencies of heating, cooling and service water heating equipment. Where a gas-direct unvented room heater, electric furnace or baseboard electric heater is installed in the resident, the label shall list "gas-fired unvented room heater," "electric furnace" or "baseboard electric heater," as appropriate. An efficiency rating shall not be listed for gas-fired unvented room heaters, electric furnaces or electric baseboard heaters. The label shall include the completion date, builder company name and the license number assigned by the Arkansas Contractor's Licensing Board. The label will serve as an indication the home, at the time of completion, is in compliance with this Code. Copies of this label shall also be provided to the lender and appraiser. If requested, copies shall be provided to realtors and others stakeholders involved with the transaction.

401.3.1 Label maintenance. The Arkansas Economic Development Commission - Energy Office shall create and maintain the label. Alterations by the Arkansas Economic Development Commission - Energy Office to this label cannot increase or decrease the stringency of the standards reflected in this Code. The version number of the label must be clearly stated in the bottom left corner of the label. The label can include other energy related information from various rating systems, designations and local utility programs. The label must be made available by the Arkansas Economic Development Commission - Energy Office to the public on its website, through E-mail and by other means.

**SECTION 402
BUILDING THERMAL ENVELOPE**

***Revise Table 402.1.1, 'INSULATION AND FENESTRATION REQUIREMENTS BY COMPONENT'^a as follows:**

Revise values for Climate Zone 4 with the values below.

CLIMATE ZONE	FENSTRATION U-FACTOR ^b	SKYLIGHT ^b U-FACTOR	SKYLIGHT GLAZED FENESTRATION SHGC ^{b, e}	CEILING R-VALUE	WOOD FRAME WALL R-VALUE	MASS WALL R-VALUE ^f	FLOOR R-VALUE	BASEMENT ^b WALL R-VALUE	SLAB ^d R-VALUE & DEPTH	CRAWL SPACE ^c WALL R-VALUE
4 except Marine	.50	.65	.30	30	13	5/10	19	10/13	0	5/13

**SECTION 403
SYSTEMS**

***Delete Section 403.1.1, 'Programmable thermostat.'**

***Add new Section 403.2.1.1 'Spray foam insulation.'**

403.2.1.1 Spray foam insulation. Spray application of polyurethane foam to the exterior of ducts in attics and crawl spaces shall be permitted subject to all of the following:

1. The flame spread index is not greater than 25 and the smoke-developed index is not greater than 450 at the specified installed thickness.
2. The foam plastic is protected in accordance with the ignition barrier requirements.
3. The foam plastic complies with the requirements of Section R316.
4. Duct coverings and linings shall not flame, glow, smolder or smoke when tested in accordance with ASTM C 411 at the temperature to which they are exposed in service. The test temperature shall not fall below 250°F (121°C). Coverings and linings shall be listed and labeled.
5. External duct insulation and factory-insulated flexible ducts shall be legibly printed or identified at intervals not longer than 36 inches (914 mm) with the name of the manufacturer, the thermal resistance R-value at the specified installed thickness and the flame spread and smoke-developed indexes of the composite materials. Spray polyurethane foam manufacturers shall provide the same product information and properties, at the nominal installed thickness, to the customer in writing at the time of foam application. All duct insulation product R-values shall be based on insulation only, excluding air films, vapor retarders or other duct components, and shall be based on tested C-values at 75°F (24°C) mean temperature at the installed thickness, in accordance with recognized industry procedures. The installed thickness of duct insulation used to determine its R-value shall be determined as follows:
 6. For duct board, duct liner and factory-made rigid ducts not normally subjected to compression, the nominal insulation thickness shall be used.
 7. For ductwrap, the installed thickness shall be assumed to be 75 percent (25-percent compression) of nominal thickness.
 8. For factory-made flexible air ducts, the installed thickness shall be determined by dividing the difference between the actual outside diameter and nominal inside diameter by two.

9. For spray polyurethane foam, the aged R-value per inch measured in accordance with recognized industry standards shall be provided to the customer in writing at the time of foam application. In addition, the total R-value for the nominal application thickness shall be provided.

This section supersedes the 2010 Arkansas Mechanical Code.

***Revise section 403.2.2 Sealing (Mandatory) as follows:**

403.2.2 Sealing (Mandatory). All ducts, air handlers, filter boxes and building cavities used as ducts shall be sealed. Joints and seams shall comply with Section M1601.4.1 of the International Residential Code. Verification of compliance with this Section shall be in accordance with either Section 403.2.2.1 or 403.2.2.2.

***Add new section 403.2.2.1 Testing Optional**

403.2.2.1 Testing Option. Duct tightness and insulation installation shall be considered acceptable when it is verified by either of the following:

1. **Postconstruction test:** Leakage to outdoors shall be less than or equal to 8 cfm (226.5 L/min) per 100 ft² (9.29 m²) of conditioned floor area or a total leakage less than or equal to 12 cfm (12 L/min) per 100 ft² (9.29 m²) of conditioned floor area when tested at a pressure differential of 0.1 inches w.g. (25 Pa) across the entire system, including the manufacturer's air handler enclosure. All register boots shall be taped or otherwise sealed during the test.
2. **Rough-in test:** Total leakage shall be less than or equal to 6 cfm (169.9 L/min) per 100 ft² (9.29 m²) of conditioned floor area when tested at a pressure differential of 0.1 inches w.g. (25 Pa) across the roughed in system, including the manufacturer's air handler enclosure. All register boots shall be taped or otherwise sealed during the test. If the air handler is not installed at the time of the test, total leakage shall be less than or equal to 4 cfm (113.3 L/min) per 100 ft² (9.29 m²) of conditioned floor area.

The results from these leakage tests are used at the time of initial inspection only while in the care of the builder. Leakage tests at a later date cannot be used to claim non-compliance with this Code.

Duct tightness shall be considered acceptable with the requirements of Section 403.2.2 are field verified. Where required by the code official, an approved party independent from the installer of the insulation shall inspect the duct sealing.

Exceptions:

1. Duct tightness test is not required if the air handler and all ducts are located within the conditioned space.
2. Duct tightness testing is not required for existing duct systems unless more than 50% of duct system is modified.
3. If the air handler, furnace or evaporator coil is replaced on an existing system, all joints, seams and connections from equipment to duct system and duct system connections to plenums shall meet the sealing requirements of this Code and be verified by a visual inspection by the code official or HVACR installer licensed by the State of Arkansas.

***Revise 403.2.3 'Building cavities (Mandatory)' to read as follows:**

403.2.3 Building cavities (Mandatory). Building framing cavities shall not be used as supply or return ducts. All supply and return ducts must be lined with metal, ductboard or other material approved in AMC 603.

***Add new Section 403.2.4, 'Joints and seams', to read as follows:**

403.2.4 Joints and seams. Joints of duct systems shall be made substantially airtight by means of tapes, mastics, liquid sealants, gasketing or other approved closure systems. Without exception all closure systems shall have mastic applied that is at least 0.08 inches (2 mm) thick. Closure systems used with rigid fibrous glass ducts shall comply with UL181A and shall be marked 181A-P for pressure-sensitive tape used with mastic, 181A-M for only mastic or 181 AH for heat-sensitive tape used with mastic. Closure systems used with flexible air ducts and flexible air connectors shall comply with UL181B and shall be marked 181B-FX for pressure sensitive tape used with mastic or 181B-M for only mastic. Duct connections to flanges of air distribution system equipment or sheet metal fittings shall use mastic and be mechanically fastened. Mechanical fasteners for use with flexible nonmetallic air ducts shall comply with UL 181B at least 1-1/2 inches (38 mm) and shall use mastic and be mechanically fastened by means of at least three sheet-metal screws or rivets equally spaced around the joint. Closure systems used to seal metal ductwork shall be installed in accordance with the manufacturer's installation instructions.

Exceptions:

1. Application of spray polyurethane foam insulation and mastic shall be permitted without additional joint seals.
2. Where a duct connection is made that is partially inaccessible, three screws or rivets shall be equally spaced on the exposed portion of the joint so as to prevent a hinge effect. Mastic must be applied on all accessible sides.
3. Continuously welded or locking type longitudinal joints and seams in ducts operating at static pressures less than 2 inches of water column (500Pa) pressure classification shall not require additional closure systems.

***Delete Section 404.1, 'Lighting equipment (Prescriptive)'**

Chapter 5: Commercial Energy Efficiency

CHAPTER 5 COMMERCIAL ENERGY EFFICIENCY

*Replace mentions of the *International Mechanical Code* with the *Arkansas Mechanical Code* in the following in Sections 503.25 'Ventilation', '5013.2.6 'Energy recovery ventilation systems', 503.2.7 'Duct and plenum insulation and sealing', 503.2.7.1 'Duct construction', 503.2.7.1.1 'Low-pressure duct systems', 503.2.7.1.2 'Medium-pressure duct systems', '503.2.9.1 "Air system balancing", 503.3.1 'Economizers', and 503.4.5 'Requirements for complex mechanical systems serving multiple zones.'

Chapter 6: Referenced Standards

**CHAPTER 6
REFERENCED STANDARDS**

*Revise Chapter 6 ‘Referenced Standards’ to include the following:

AFC Arkansas Fire Prevention Code
 State Fire Marshal’s Office
 1 State Police Plaza Drive
 Little Rock, Arkansas 72209
 (501) 618-8621

Standard reference number	Title	Referenced in Code section number
AFC	Arkansas Fire Prevention Code.....	103.6

AMC Arkansas Mechanical Code
 Department of Health
 Division of Protective Health Codes
 4815 West Markham Street, Slot 24
 Little Rock, Arkansas 72205-3867
 (501)661-2642

Referenced in Code section number

AMC	Arkansas Mechanical Code.....	503.2.5,503.2.5.1, 503.2.6, 503.2.7, 503.2.7.1, 503.2.7.1.1, 503.2.7.1.2, 503.2.9.1, 503.1 and 503.4.5
-----	-------------------------------	--

Appendices

Appendices are not enforceable unless they are specifically referenced in the body of the code or local authority having jurisdiction. These are included to be helpful in meeting and understanding the *2014 Arkansas Energy Code*.

APPENDIX A:

***Add new Appendix A, 'SAMPLE ORDINANCE'**

APPENIX B:

***Add new Appendix B, 'AIR SEALING KEY POINTS'**

This space intentionally left blank.

APPENDIX A: SAMPLE ORDINANCE

ORDINANCE NO. _____

AN ORDINANCE PROVIDING MINIMUM ENERGY STANDARDS FOR THE DESIGN OF NEW BUILDINGS AND STRUCTURES OR PORTIONS AND ADDITIONS TO EXISTING BUILDINGS THAT PROVIDE FACILITIES OR SHELTER FOR PUBLIC ASSEMBLY, EDUCATION, BUSINESS, MERCANTILE, INSTITUTIONAL, STORAGE, AND RESIDENTIAL OCCUPANCIES, AS WELL AS THOSE PORTIONS OF FACTORY AND INDUSTRIAL OCCUPANCIES DESIGNED PRIMARILY FOR HUMAN OCCUPANCY BY REGULATING THEIR EXTERIOR ENVELOPES AND THE SELECTION OF THEIR HVAC, SERVICE WATER HEATING, ELECTRICAL DISTRIBUTION AND ILLUMINATING SYSTEMS AND EQUIPMENT FOR EFFECTIVE USE OF ENERGY.

Be in enacted by the City Council of _____, Arkansas,

Section 1. ADOPTION OF ENERGY CODE.

There is hereby adopted by the City Council of _____, Arkansas, for the purpose of establishing rules and regulations for energy efficient standards for new building construction, this Code known as the 2014 Arkansas Energy Code, being particularly the 2014 Arkansas Energy Code edition thereof and the whole thereof, save and except such portions as are hereinafter deleted, modified, or amended, of which not less than three (3) copies of this ordinance, as well as, three (3) copies of the 2014 Arkansas Energy Code, have been and now are filed in the office of the Clerk or Recorder of the city of _____, Arkansas, and the same ordinance is hereby adopted and incorporated as fully as if set out at length herein, and from the date on which this ordinance shall take effect, the provisions thereof shall be controlling in the construction of all buildings and structures therein contained within the corporate limits of the City of _____, Arkansas.

Section 2. INCONSISTENT ORDINANCES REPEALED.

Ordinances or parts thereof in force at the time that this ordinance shall take effect, if inconsistent herewith, are hereby repealed.

Section 3. EMERGENCY CLAUSE.

Whereas it is of the utmost urgency that the city of _____, Arkansas, have an up-to date Energy Code to protect the citizens of our city, therefore, an Emergency is hereby declared to exist and this ordinance being necessary for the immediate protection of the public shall take effect immediately on its passage and approval.

Signed: _____
Mayor
(SEAL)

Attest: _____
City Clerk or Recorder
Date Passed: _____

APPENDIX B: AIR SEALING KEY POINTS

Guide and illustrations provided by Southface Energy Institute, Inc.

Air Barrier and Insulation Inspection Component Guide

NUMBER	COMPONENT	CRITERIA
1	Air barrier and thermal barrier	Exterior thermal envelope insulation for framed walls is installed in substantial contact and continuous alignment with building envelope air barrier. Breaks or joints in the air barrier are filled or repaired. Air-permeable insulation is not used as a sealing material. Air-permeable insulation is inside of an air barrier.
2	Ceiling/attic	Air barrier in any dropped ceiling/soffit is substantially aligned with insulation and any gaps are sealed. Attic access (except unvented attic), knee wall door, or drop down stair is sealed.
3	Walls	Corners and headers are insulated. Junction of foundation and sill plate is sealed.
4	Windows and doors	Space between window/door jambs and framing is sealed.
5	Rim joists	Rim joists are insulated and include an air barrier.
6	Floors (including above-garage and cantilevered floors)	Insulation is installed to maintain permanent contact with underside of subfloor decking. Air barrier is installed at any exposed edge of insulation.
7	Crawl space walls	Insulation is permanently attached to walls. Exposed earth in unvented crawl spaces is covered with Class I vapor retarder with overlapping joints taped.
8	Shafts, penetrations	Duct shafts, utility penetrations, knee walls and flue shafts opening to exterior or unconditioned space are sealed.
9	Narrow cavities	Batts in narrow cavities are cut to fit, or narrow cavities are filled by sprayed/blown insulation.
10	Garage separation	Air sealing is provided between the garage and conditioned spaces.
11	Recessed lighting	Recessed light fixtures are air tight, IC rated, and sealed to drywall. Exception—fixtures in conditioned space.
12	Plumbing and wiring	Insulation is placed between outside and pipes. Batt insulation is cut to fit around wiring and plumbing, or sprayed/blown insulation extends behind piping and wiring.
13	Shower/tub on exterior wall	Showers and tubs on exterior walls have insulation and an air barrier separating them from the exterior wall.
14	Electrical/phone box on exterior walls	Air barrier extends behind boxes or air sealed-type boxes are installed.
15	Common wall	Air barrier is installed in common wall between dwelling units.
16	HVAC register boots	HVAC register boots that penetrate building envelope are sealed to subfloor or drywall.
17	Fireplace	Fireplace walls include an air barrier.

Disclaimer:
This document is intended solely to help graphically demonstrate the air leakage provisions of section 402.4 of the 2009 IECC. It does not cover all airsealing locations or techniques. Other code provisions may be applicable as well.

Air sealing key points

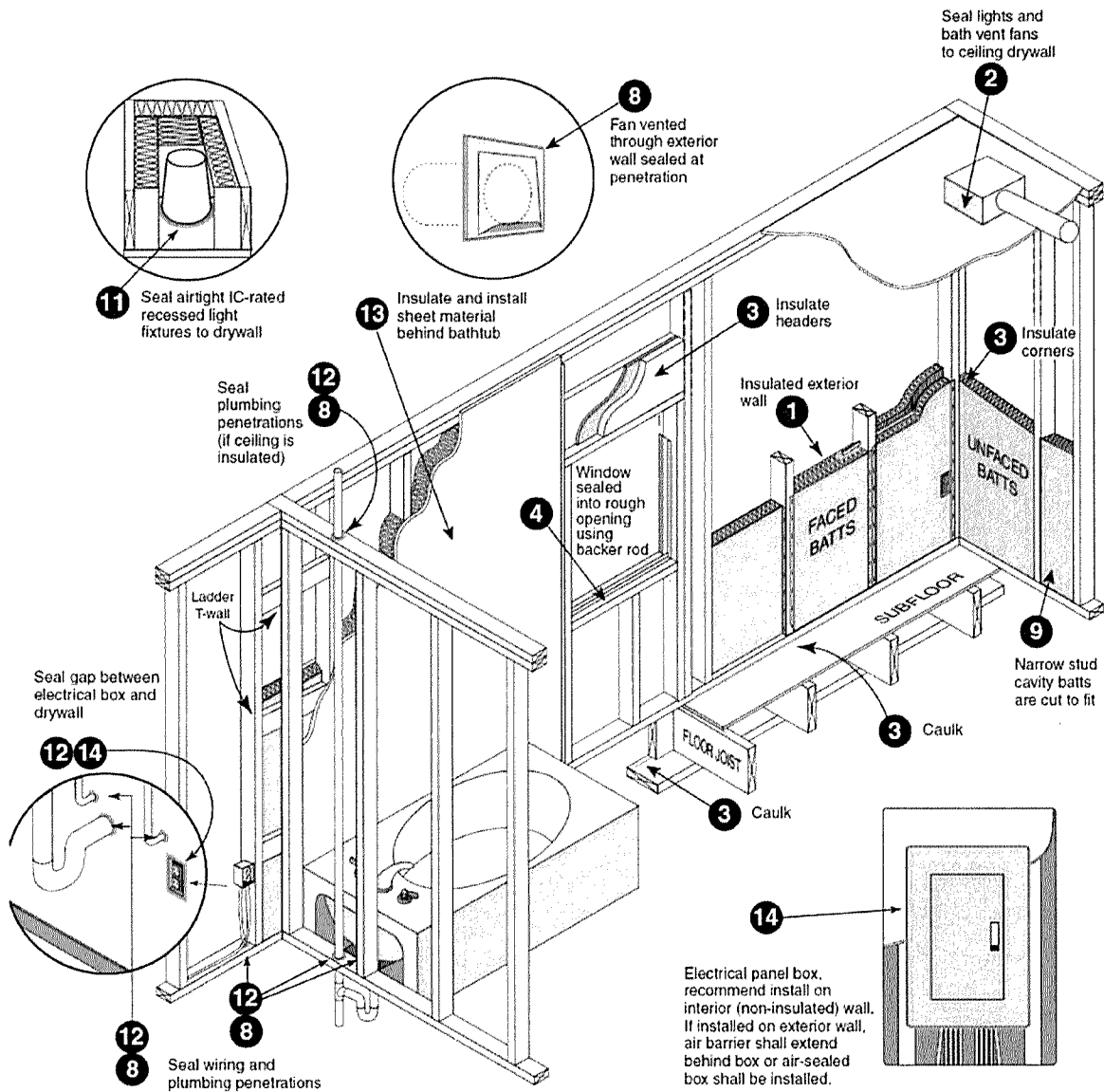

Disclaimer:
 This document is intended solely to help graphically demonstrate the air leakage provisions of section 402.4 of the 2009 IECC. It does not cover all airsealing locations or techniques. Other code provisions may be applicable as well.

Air sealing key points *continued*

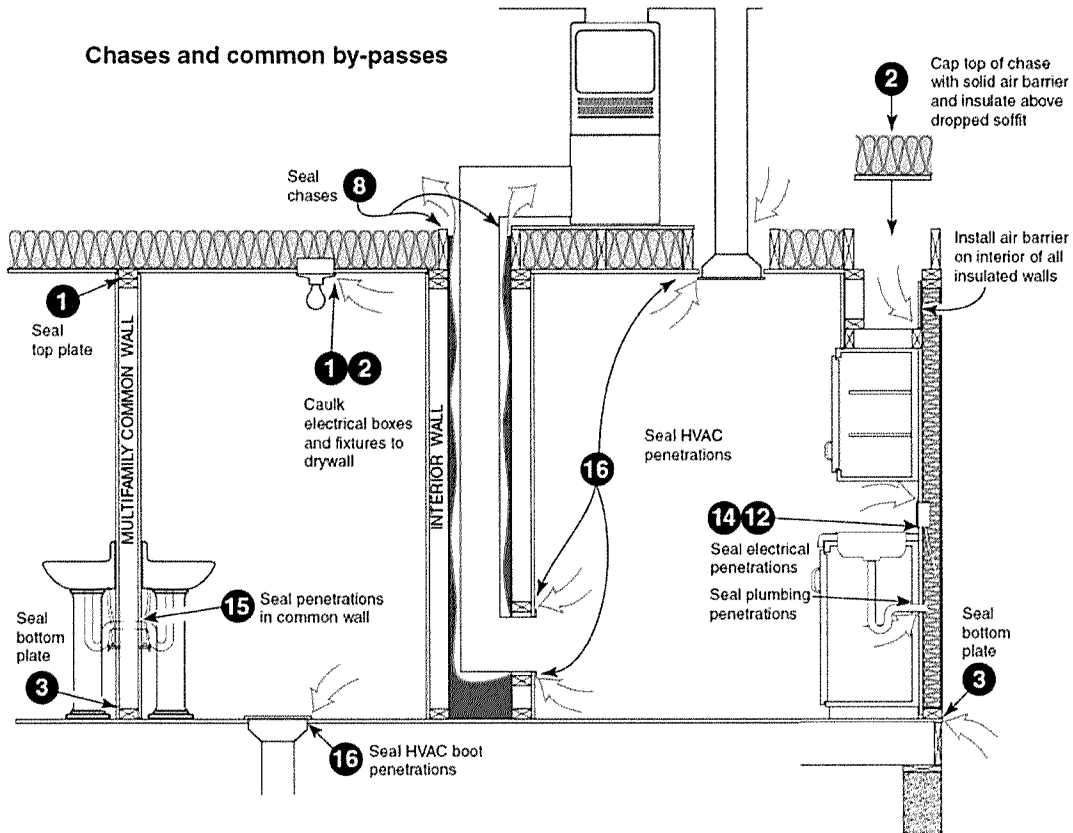

Shower/tub drain rough opening

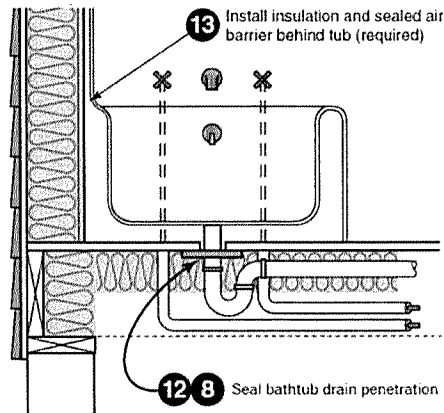

Disclaimer:
 This document is intended solely to help graphically demonstrate the air leakage provisions of section 402.4 of the 2009 IECC. It does not cover all airsealing locations or techniques. Other code provisions may be applicable as well.

Air sealing key points *continued*

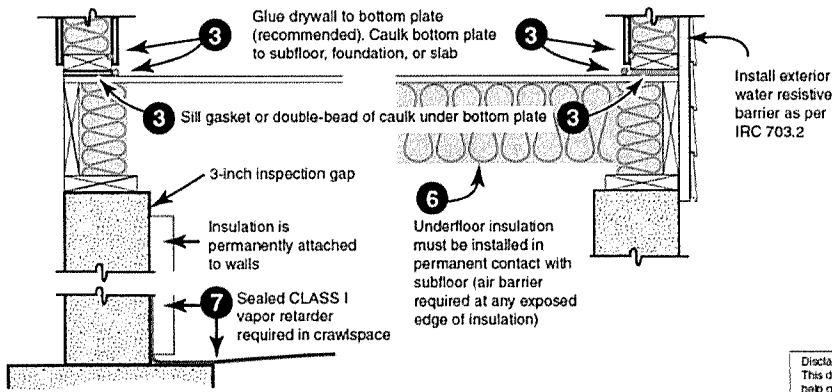
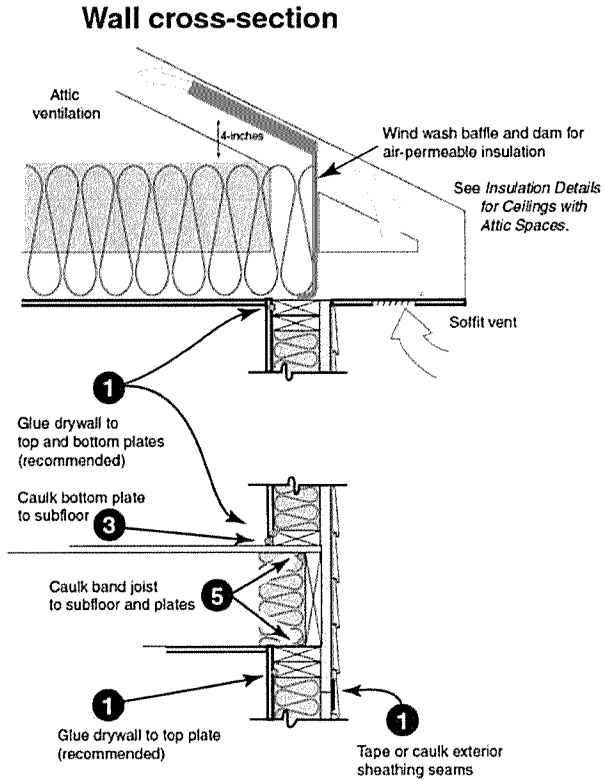
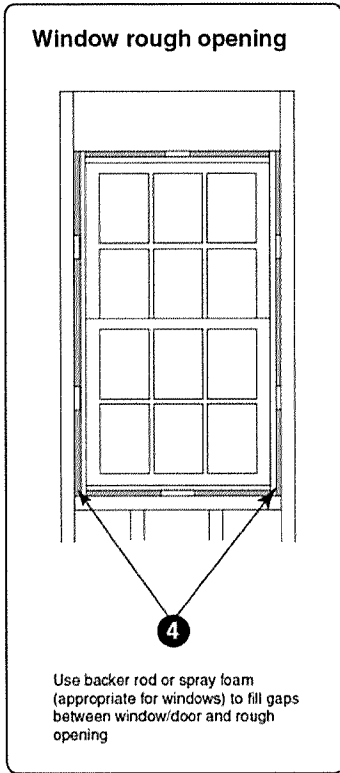

Disclaimer:
This document is intended solely to help graphically demonstrate the air leakage provisions of section 402.4 of the 2009 IECC. It does not cover all airsealing locations or techniques. Other code provisions may be applicable as well.

Air sealing key points *continued*

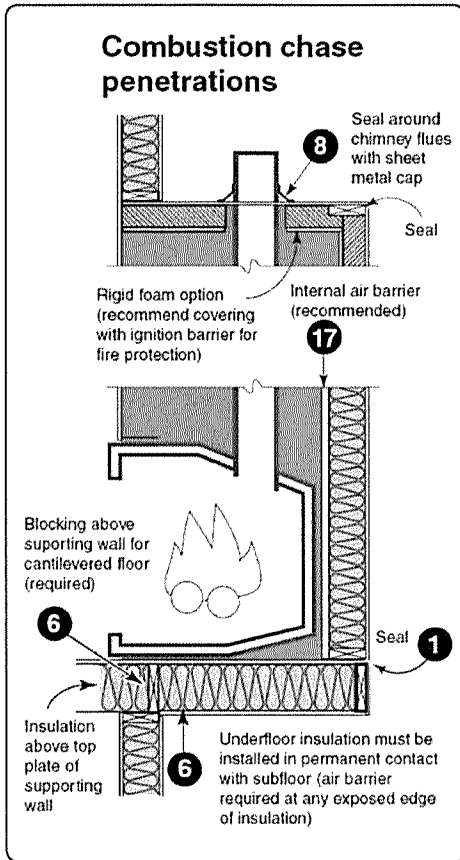

Exterior penetrations

8 12 Caulk exterior wall penetrations for refrigeration lines, condensate line, etc.

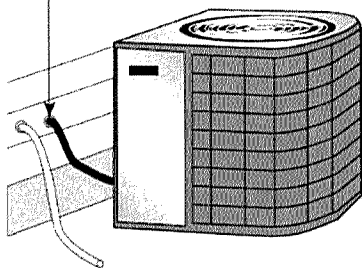

5

Combustion closet

Combustion air inlets
as per mechanical and/or fuel gas code

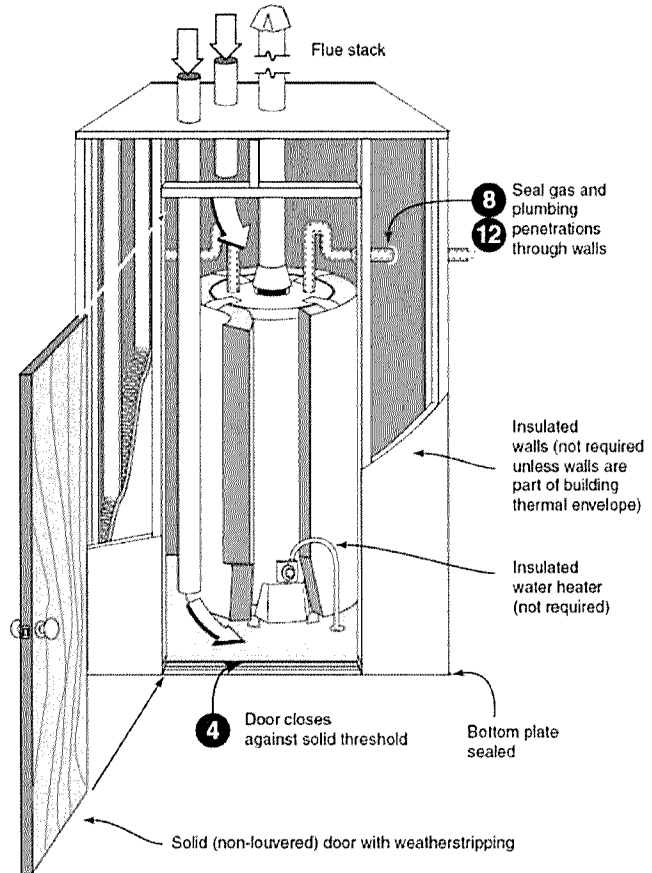

Disclaimer:
This document is intended solely to help graphically demonstrate the air leakage provisions of section 402.4 of the 2009 IECC. It does not cover all airsealing locations or techniques. Other code provisions may be applicable as well.

Air sealing key points *continued*

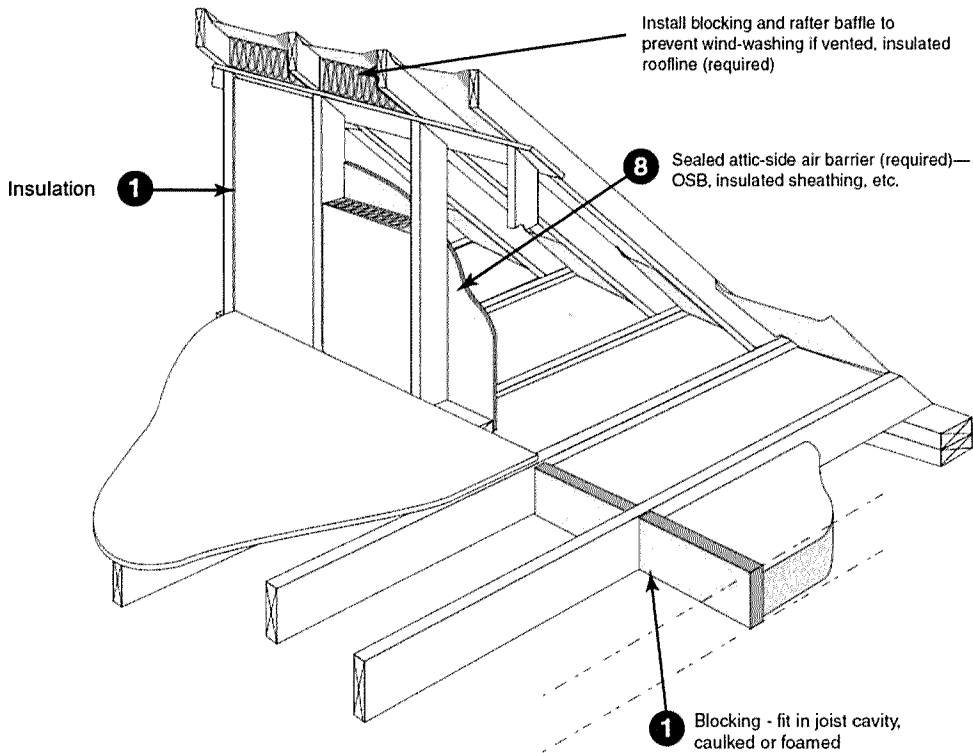

Attic knee-walls

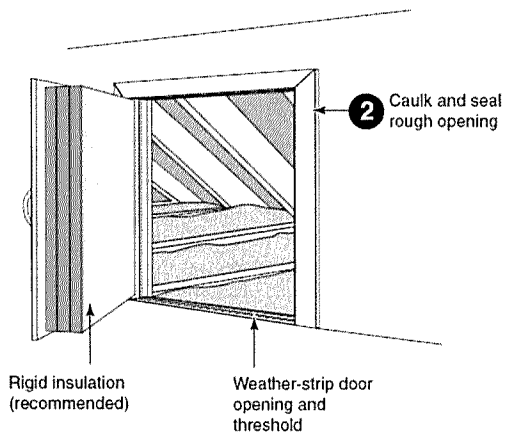

Two-level attic

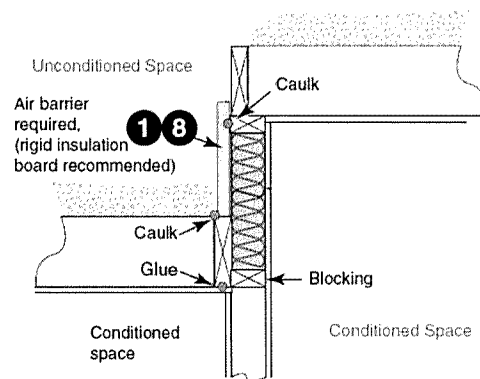

Disclaimer:
This document is intended solely to help graphically demonstrate the air leakage provisions of section 402.4 of the 2009 IECC. It does not cover all airsealing locations or techniques. Other code provisions may be applicable as well.

Air sealing key points *continued*

Attic scuttle

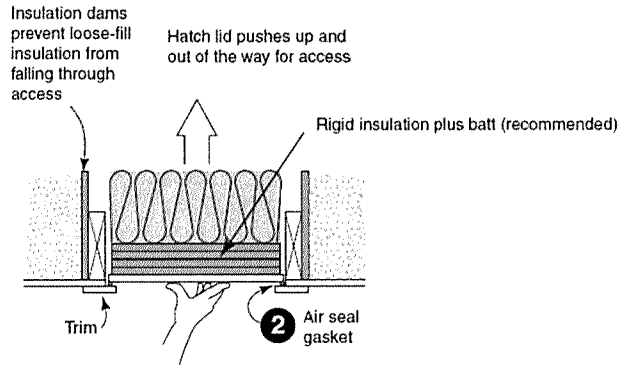

Attic pull-down stairs

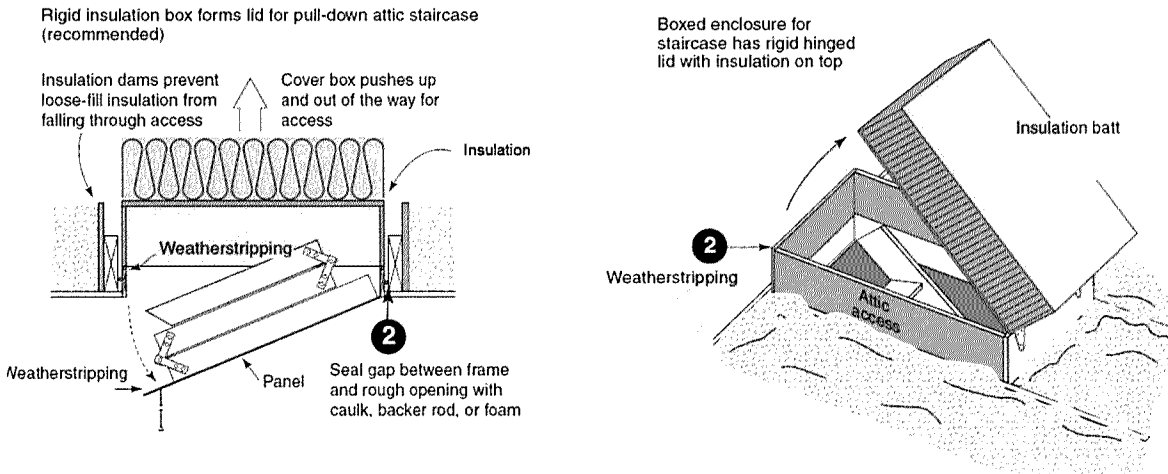

Attic pull-down stairs

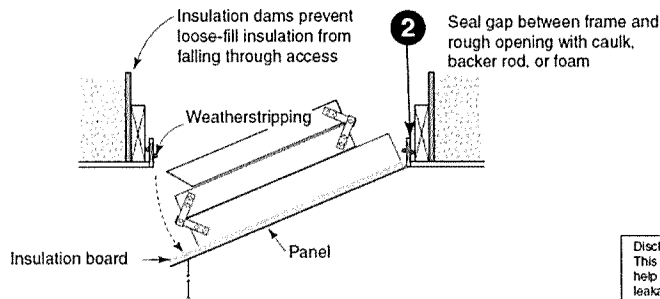

Disclaimer:
 This document is intended solely to help graphically demonstrate the air leakage provisions of section 402.4 of the 2009 IECC. It does not cover all air-sealing locations or techniques. Other code provisions may be applicable as well.

Air sealing key points *continued*

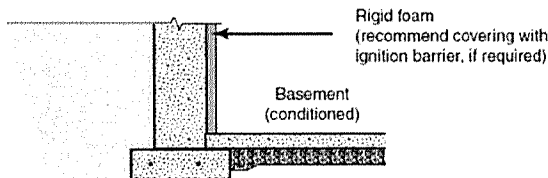
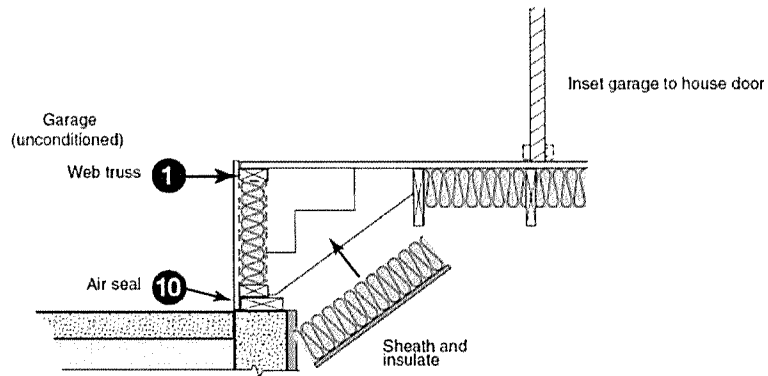
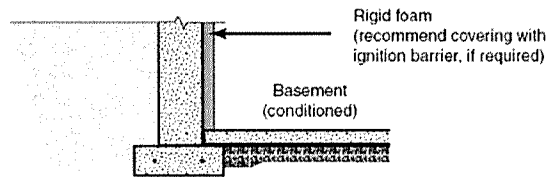
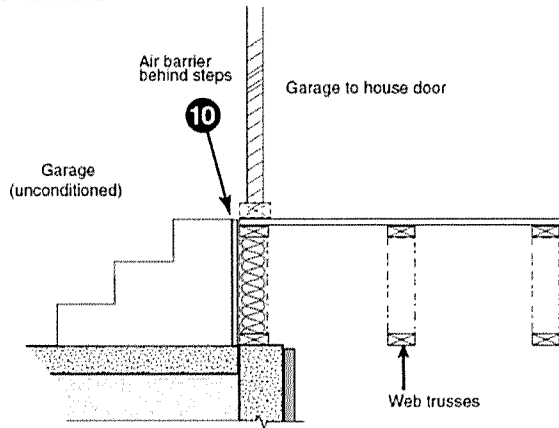

Disclaimer:
 This document is intended solely to help graphically demonstrate the air leakage provisions of section 402.4 of the 2009 IECC. It does not cover all airsealing locations or techniques. Other code provisions may be applicable as well.

Air sealing key points *continued*

Mechanical Closet

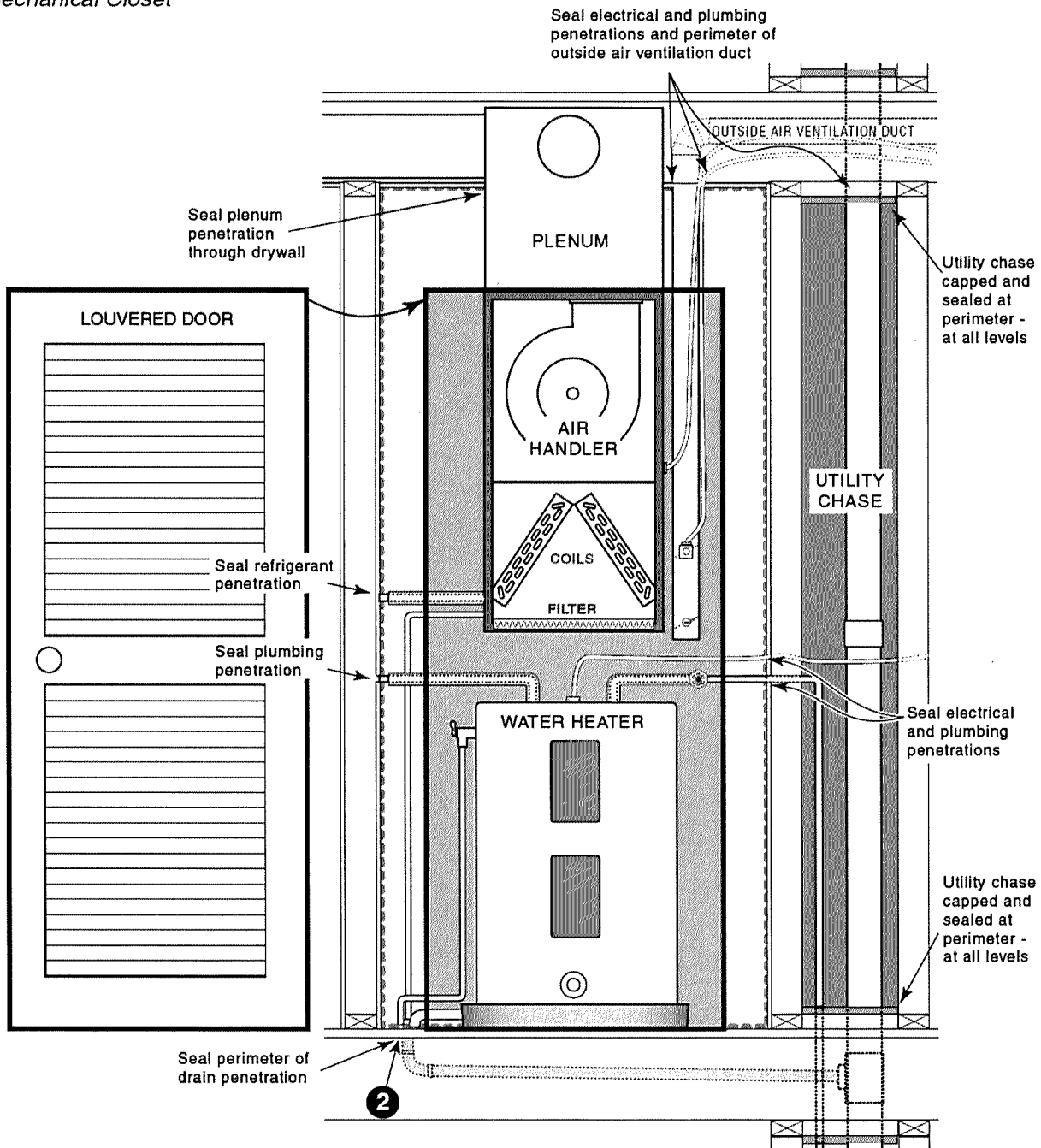

Disclaimer:
 This document is intended solely to help graphically demonstrate the air leakage provisions of section 402.4 of the 2009 IECC. It does not cover all airsealing locations or techniques. Other code provisions may be applicable as well.

Air sealing key points *continued*
Multifamily

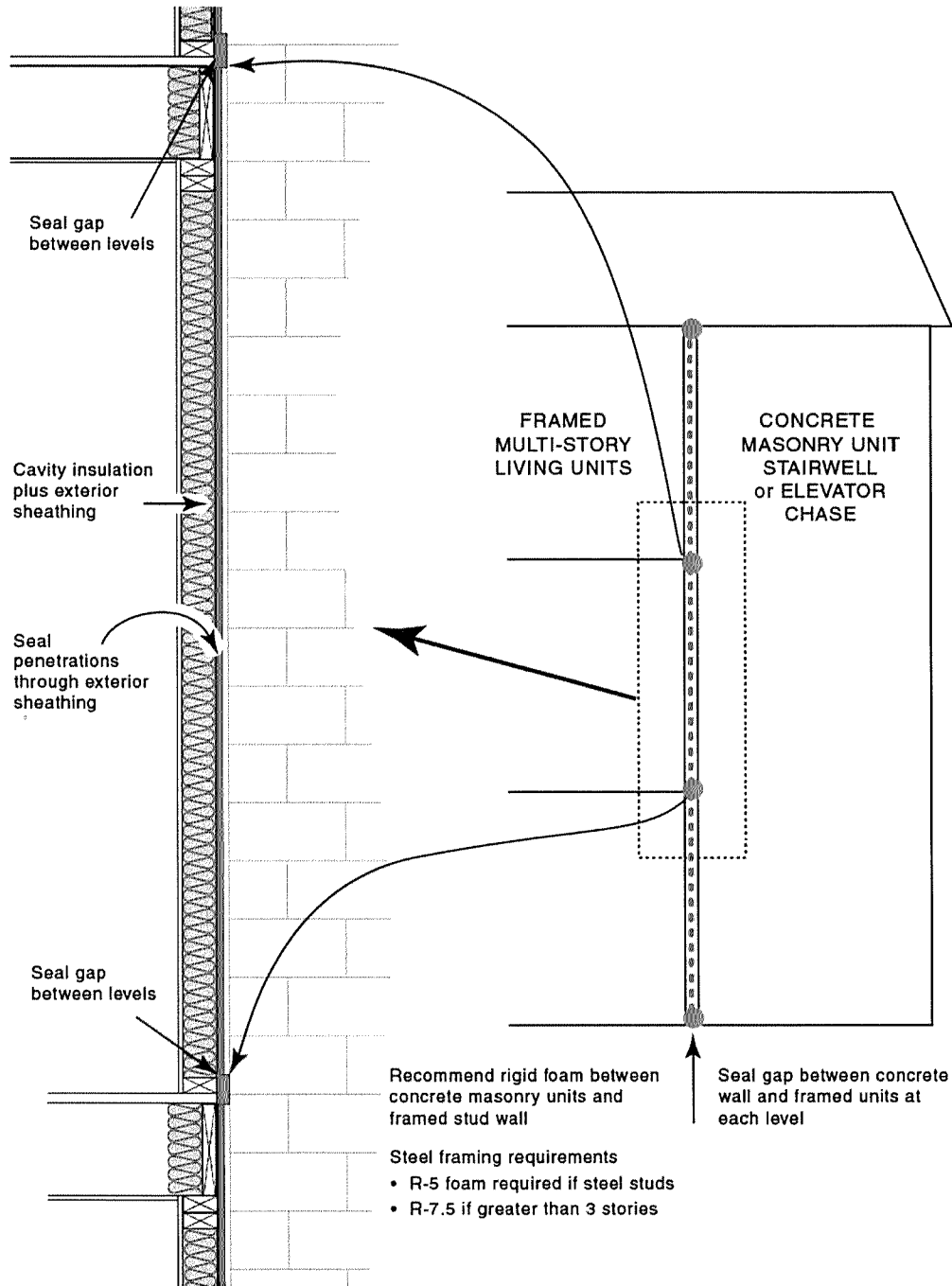

Disclaimer:
 This document is intended solely to help graphically demonstrate the air leakage provisions of section 402.4 of the 2009 IECC. It does not cover all airsealing locations or techniques. Other code provisions may be applicable as well.

Building Thermal Envelope — The basement walls, exterior walls, floor, roof, and any other building element that enclose conditioned space. This boundary also includes the boundary between conditioned space and any exempt or unconditioned space. —2009 IECC

The *building thermal envelope* is the barrier that separates the conditioned space from the outside or unconditioned spaces. The building envelope consists of two parts - an air barrier and a thermal barrier that must be both continuous and contiguous (touching each other). In a typical residence, the building envelope consists of the roof, walls, windows, doors, and foundation. Examples of unconditioned spaces include attics, vented crawlspaces, garages, and basements with ceiling insulation and no HVAC supply registers.

Example 1

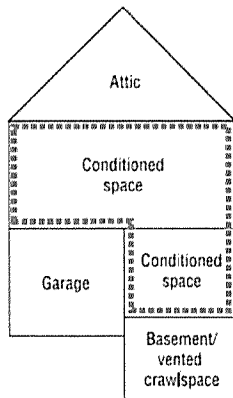

This is a conventional approach that likely locates all ductwork in unconditioned spaces.

Example R-values¹

- Flat ceiling: R-30
- Exterior walls: R-13 + R-3 sheathing
- Floor over garage and basement/crawl: R-19
- Ductwork sealed with mastic and insulated
- Garage⁵, attic and basement/crawl are unconditioned spaces

Example 2

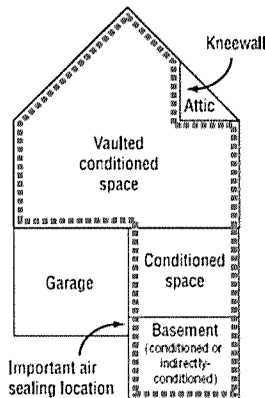

If supply registers deliver conditioned air to basement, it is considered conditioned. With no supply air, it is considered an indirectly-conditioned space.

Example R-values¹

- Flat ceiling: R-38
- Kneewalls²: R-18 (required) (R-13+ R-5, R-15 + R-3, R-19 in 2x6)
- Vaulted ceiling³: R-19 air-permeable insulation plus R-5 rigid foam board
- Exterior walls: R-13
- Basement masonry walls: R-5
- Basement slab⁴: R-0
- Ductwork sealed with mastic and insulated
- Garage⁵ and attic are unconditioned spaces

Example 3

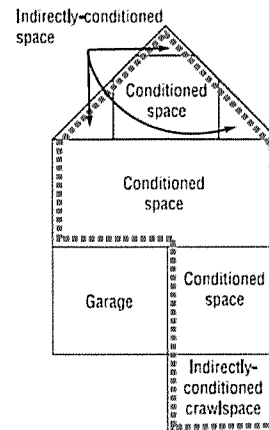

The top conditioned floor functions as a vaulted ceiling with interior walls although it appears to have kneewalls and a flat ceiling. An advantage of this approach is that all upstairs ductwork is located inside the building envelope.

The crawlspace walls are insulated and do not contain vents. The crawlspace ground is covered with concrete or 100% plastic and functions as a "mini-basement."

Example R-values¹

- Vaulted ceiling³: R-19 air-impermeable foam insulation
- Exterior walls: R-13 + R-3 sheathing
- Crawlspace walls: R-5
- Ductwork sealed with mastic and insulated
- Garage⁵ is unconditioned space

Insulation Details for Ceilings with Attic spaces

Rafter and Truss

Standard Truss with tapered insulation depth

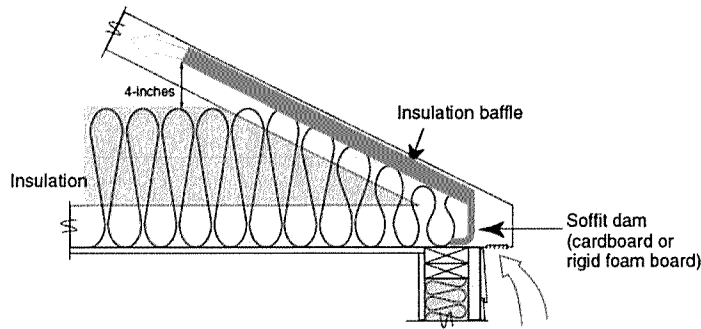

Energy Truss with full height insulation (recommended)

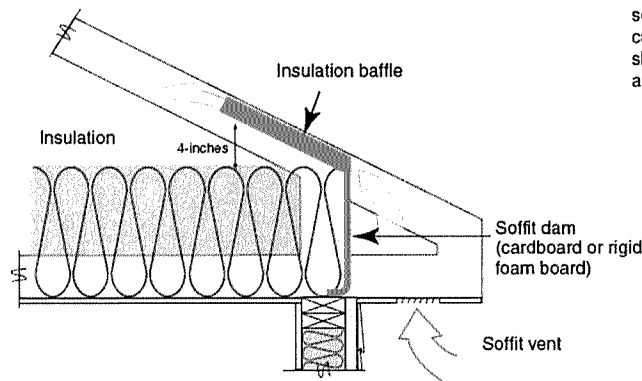

Standard rafter and top plate with tapered insulation depth

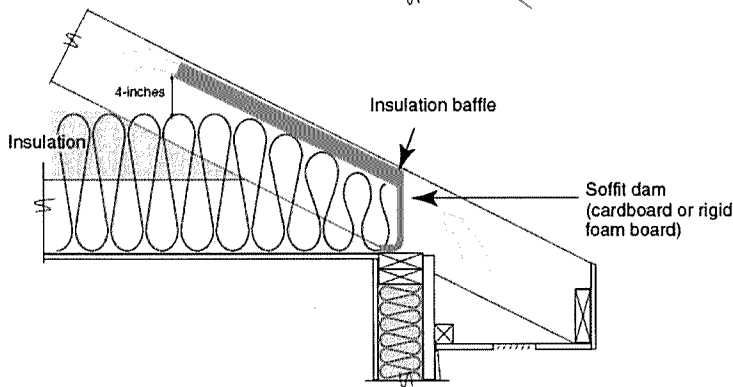

Rafter on raised top plate with full height insulation (recommended)

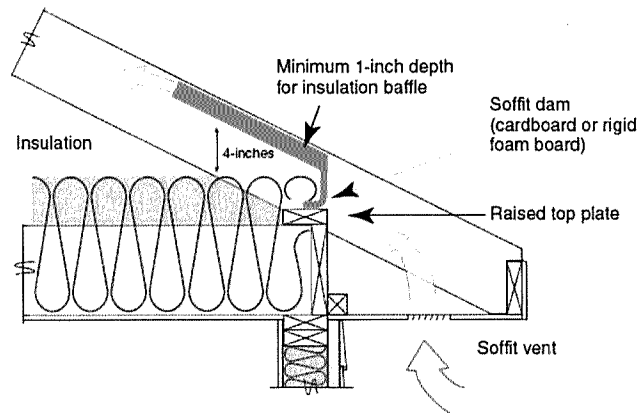

Note: Wind wash baffle and air-permeable insulation dam. For air permeable insulation in vented attics, baffles shall be installed adjacent to soffit and eave vents. A minimum of a 1-inch of space shall be provided between the insulation and the roof sheathing and at the location of the vent. The baffle shall extend over the top of the insulation inward until it is at least 4 inches vertically above the top of the insulation. Any solid material such as cardboard or thin insulating sheathing shall be permissible as the baffle.

Disclaimer:
This document is intended solely to help graphically demonstrate the air leakage provisions of section 402.4 of the 2009 IECC. It does not cover all airsealing locations or techniques. Other code provisions may be applicable as well.

Roofline Installed Insulation Options

Air impermeable installed insulation
(e.g., spray foam insulation)

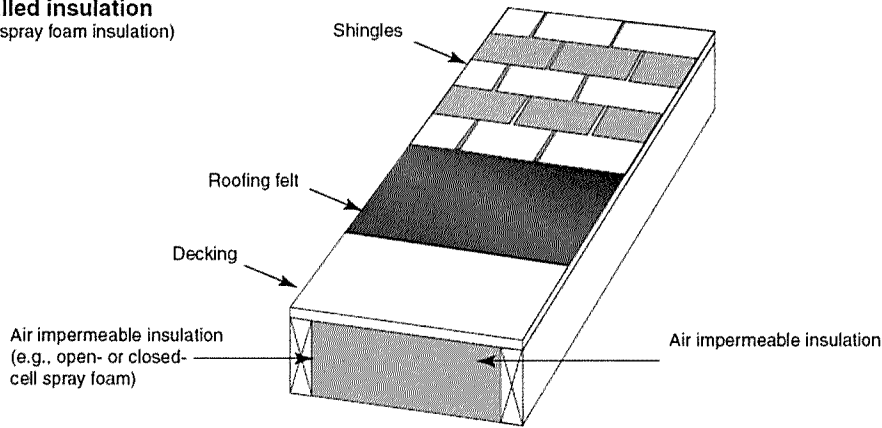

Air-permeable installed insulation
(e.g. fiberglass, cellulose)

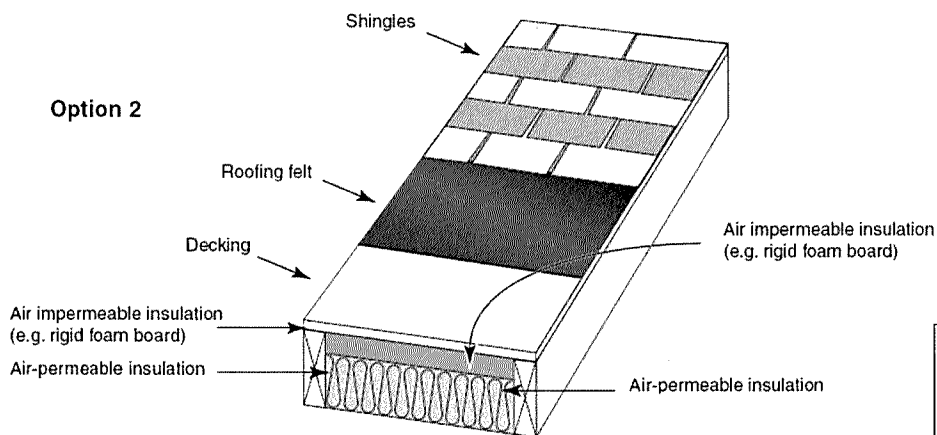
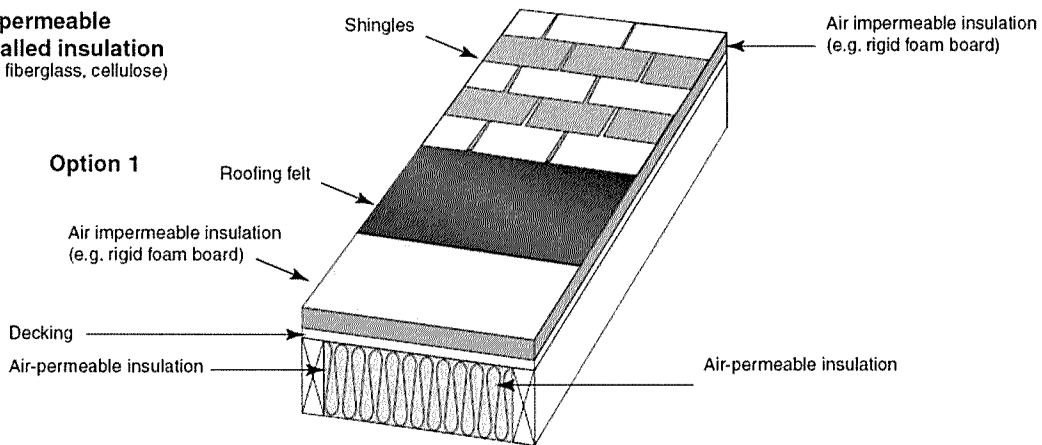

Disclaimer:
This document is intended solely to help graphically demonstrate the air leakage provisions of section 402.4 of the 2009 IECC. It does not cover all airsealing locations or techniques. Other code provisions may be applicable as well.